



LED GUIDANCE SIGN
Size 1, Size 2, Size 3 & Size 5
Installation Instructions

DO NOT DISCARD

Important Information for the Airport Maintenance Department

1. Locate the frangible couplings (item #1 see Underground Sign Detail) and floor flanges (#2) that are provided with the sign. (Small sign orders may be packaged in the box with the sign. Larger order will have a separate carton containing this hardware). Coat the threads of the frangible coupling with anti-seize compound or petroleum jelly. Then screw them hand tight into the floor flanges.

Note: It is also crucial that the correct couplings be used with the sign. The coupling size and mode are etched on the outside of the coupling. Incorrectly sized couplings will not meet FAA frangibility requirements.

2. Locate the power cord (#4). It will be visible protruding from the power leg slip fitter.

Note: The power cord and electrical components are located in the module nearest the nameplate on the end of the sign.

3. Slip the coupling/floor flange assemblies into each slip fitter (#3) on the bottom of the sign. Tighten the set screws (#5) just enough to hold them in place. Floor flanges must be oriented with mounting holes perpendicular to sign base. For the power cord leg, pull enough power cord slack from the sign to connect with the isolation transformer secondary extension cord (#6).

Note: The provided power cord is extra-long to allow exiting the sign through any leg desired.

Note: In a typical remote L-867 base can installation, the sign leg is connected to the remote can with 2" rigid galvanized steel (RGS) conduit. An isolation transformer secondary extension cord (#6) is fed through the conduit and connects the sign power cord plug to the isolation transformer secondary plug.

4. Locate the cable clamp (#7, provided with the sign for most new sign installations). Tighten the cable clamp (#7) onto the isolation transformer secondary extension cord female plug at grade level. Ensure the cable clamp side labeled "TOP" is facing up. The cable clamp should nest on the underside of the floor flange (#2) and on top of the conduit (#8) that is flush with the surface of the concrete mounting pad. Insert the power cord plug (male) into the isolating transformer secondary extension cord (female).

Note: As required by the FAA, this step, in conjunction with step 6, ensures that the power cord will be disconnected/unplugged if the sign is knocked over.



LED GUIDANCE SIGN
Size 1, Size 2, Size 3 & Size 5
Installation Instructions

DO NOT DISCARD

Important Information for the Airport Maintenance Department

5. Lift the sign upright into place on the cement pad. Use the sign as a template to locate and mark mounting holes. Place sign off to one side and install anchor bolts. Recommended anchor bolts: 3/8" x 5" for mode 2 signs, 5/8" for mode 3 signs. Position the sign over the anchor bolts and fasten the floor flanges to the cement pad with lock washers and nuts. Temporarily loosen the slip fitter set screws (#5). Tighten the frangible couplings 1/4 - 1/2 turn into the Floor Flanges with a pipe wrench. (Warning: Do not use the wrench above the shear groove.) Ensure that the sign is level and the modules are aligned by sighting down the length of the tops. Tighten the slip fitter set screws using a socket wrench.

6. Locate the strain relief clamp (#9) inside of the sign on the light bar (#10). Remove the sign cover (#11) nearest to the nameplate on the end of the sign by unscrewing the two turn fasteners (#12) and slide out the legend panels. Remove all slack in the power cord between the plug and the strain relief clamp, then tighten the set screw on the strain relief clamp. The extra cord can be coiled & put in the bottom of the sign. (As required by the FAA, this step, in conjunction with Step 4 ensures that the power cord will be disconnected/unplugged if the sign is knocked over.)

7. Electrical adjustments are now required. Power supply settings have been factory set but must be rechecked with an RMS meter once installed in the airfield environment. Please refer to the "Parts & Electrical Information" sheet for the installed lighting system. Follow the "Installation" portion of those directions to ensure that the electrical settings are correct.

8. Replace any covers removed.

Note: Sometimes, legend panels seem to obstruct the re-installation of the top covers. If panels are not engaging on the underside of the top cover into the gasket channel, please try the following:

Engage the turn fasteners loosely. With the palms of your hands, slap or "pop" the centers of the opposing panels inward simultaneously. The internal pressure should apply a force that allows the top to drop into place. Apply pressure downward on the top. The technique worked and if panels are correctly installed. The resistance to tightening the turn fasteners will be eliminated.



LUMACURVE GUIDANCE SIGN
Molded Electrical Underground

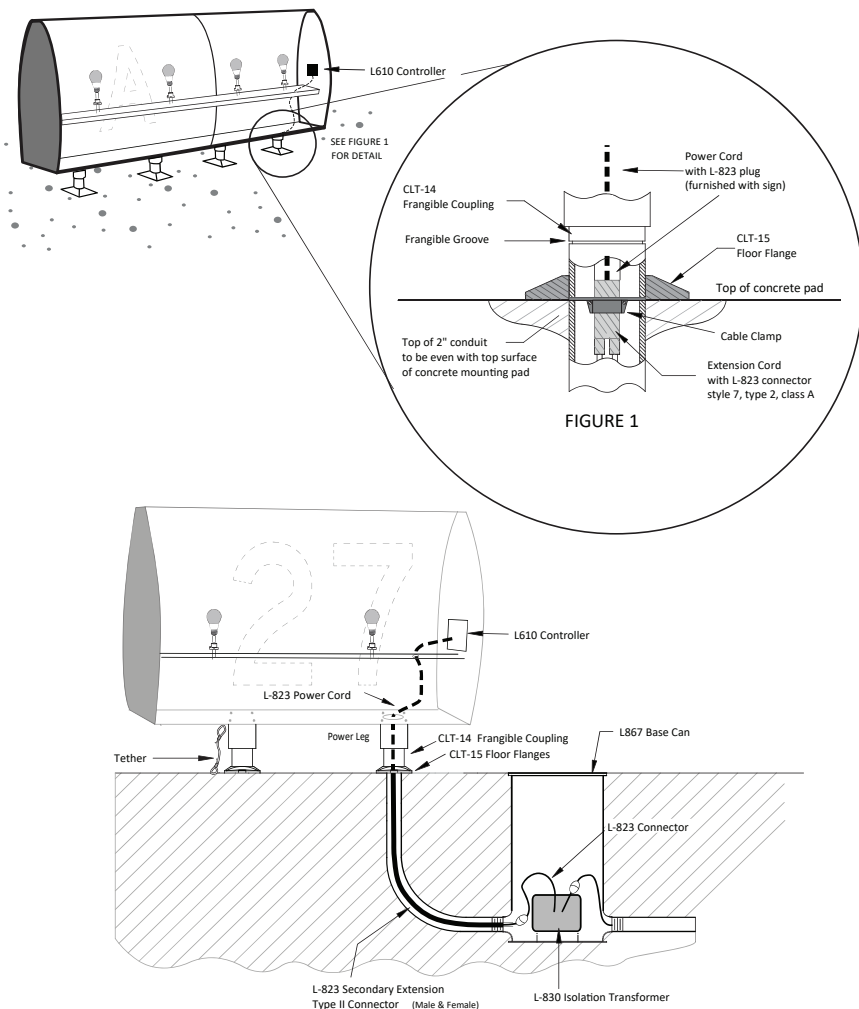

LED LIGHTING SYSTEM
Technical Information

LUMACURVE LED System

The LUMACURVE LED system maintains constant sign brightness in accordance with FAA A/C 150-5345-44 with appreciably higher efficiency relative to traditional lighting systems, and is available in new signs or in kit form for retrofit. This system delivers a constant voltage to the 4W LED lamps at all CCR current steps. This system works equally well for high intensity (Style 3, 2.8A-6.6A), medium intensity (Style 2, 4.8A-6.6A) and Style 5 (5.5A fixed) dedicated sign circuits without internal modification*. The lamps authorized for use in this system are Standard Signs, Inc. 4W LED lamps with medium screw base. They are available directly from Standard Signs, Inc.

IMPORTANT!

The LUMACURVE LED lighting system is designed exclusively for FAA styles 2, 3 & 5 operation on a series circuit together with and without non-sign fixtures, such as edge lights, where the sign brightness control components are necessary to maintain constant sign brightness regardless of CCR step.

INSTALLATION:

System lamp voltage is factory set but we recommend that one sign per CCR be spot checked with a DC voltmeter after installation. Lamp voltage is read across the lamp socket leads. If voltage varies from recommended settings (170V DC for Sizes 1, 2, 3, and 5), call and ask for technical support: 800-258-1997.

LAMP REPLACEMENT:

When a lamp fails, the controller will sense that there is a lamp out and will turn off the remaining lamps. This feature is required per current FAA specifications. With the sign energized, press and hold the lamp reset button located on the side of the controller. Release reset button immediately when lamps are energized. The sign will relight except for the failed lamp. Replace the failed lamp(s). This completes the lamp replacement process. The controller does not need to be reset again.

WARNING:

The use of non-OEM replacement lamps may damage electrical components as well as cause premature lamp failure. Only OEM Lumacurve 4W LED lamps will maintain FAA certifications and factory warranties.

DIELECTRIC GREASE:

These LED lamps are powered by a DC source and are susceptible to corrosion from moisture. We recommend the use of dielectric grease on the lamp base to prevent corrosion.

*Isolation transformer wattage requirements may vary for each application.



Certified to current FAA Advisory Circular 150/5345-44, UL Series
View our Certificate of Conformance

LED LIGHTING SYSTEM
L-610 Controller

L610 CONTROLLER

- Switch SW2 (Run & Test) is used to isolate controller programming functions when troubleshooting (1 out all out)
- Switch SW3 (Ferro & SCR) is used to set controller functions with constant current regulators (CCR's)

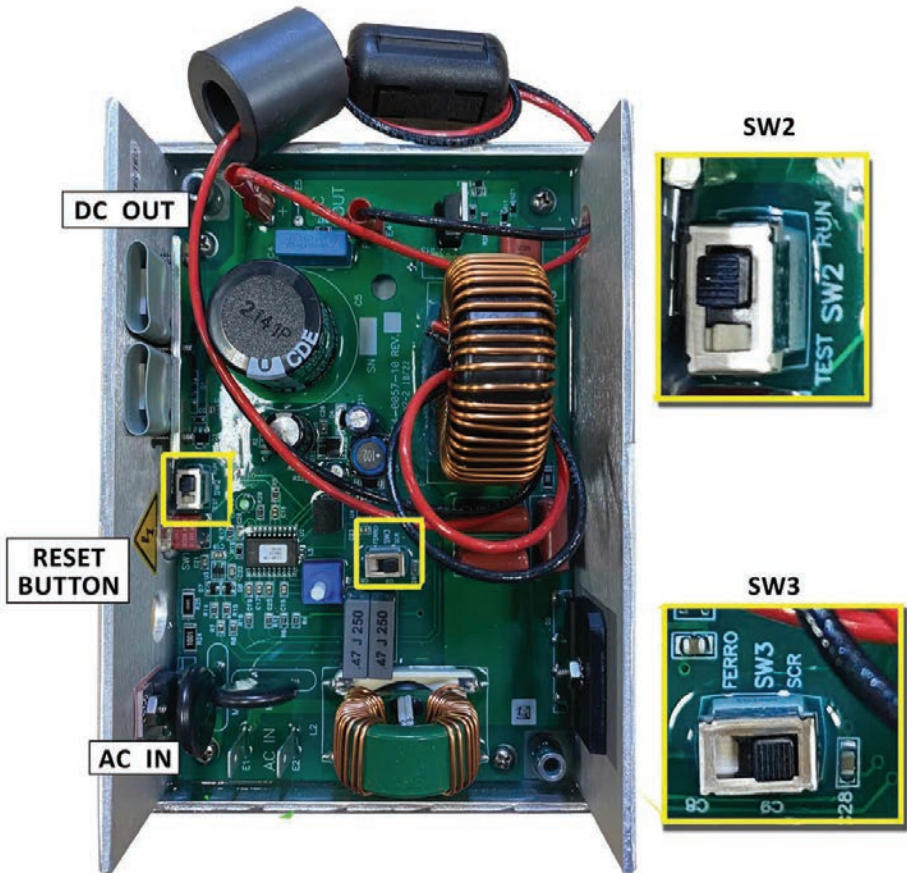

www.lumacurve.com

LED LIGHTING SYSTEM
Parts & Drawing

To order parts, or have questions, call 800-258-1997.
View reference documents, visit www.lumacurve.com/documents

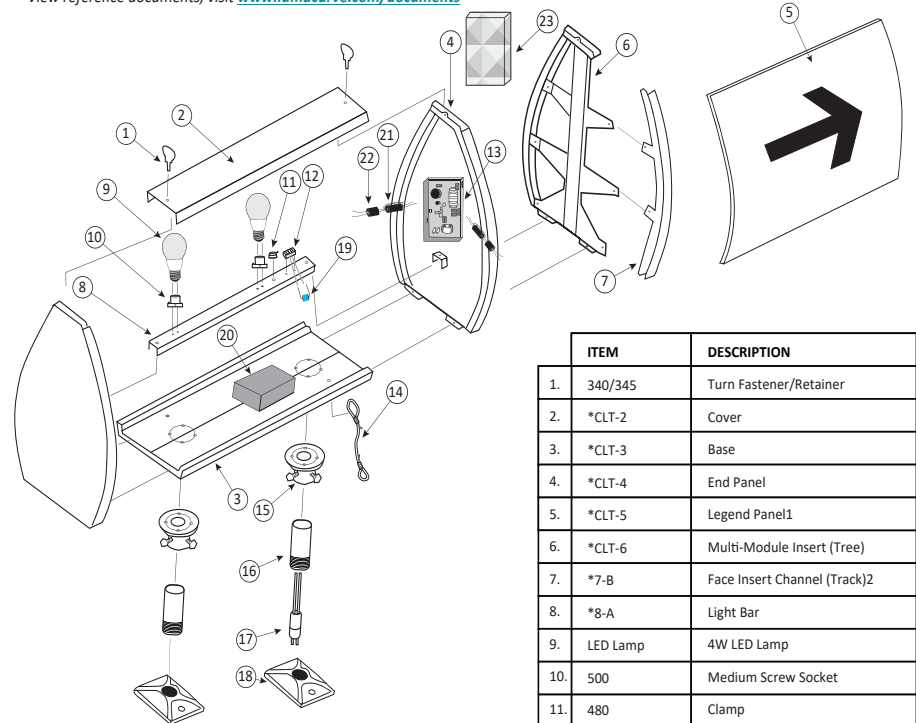

ITEM	DESCRIPTION
1.	340/345 Turn Fastener/Retainer
2.	*CLT-2 Cover
3.	*CLT-3 Base
4.	*CLT-4 End Panel
5.	*CLT-5 Legend Panel1
6.	*CLT-6 Multi-Module Insert (Tree)
7.	*7-B Face Insert Channel (Track)2
8.	*8-A Light Bar
9.	LED Lamp 4W LED Lamp
10.	500 Medium Screw Socket
11.	480 Clamp
12.	420 Terminal Strip
13.	L610 LED PCB Controller
14.	190 - 3/16" Tether
15.	130 PH Slipfitter
16.	140-S3M2 6" Frangible Coupling
17.	430 Cord & Plug
18.	15 Floor Flange
19.	E416 Surge Protector
20.	G Filter ALD Low Pass Filter
21.	G Ferrite A Ferrite Core Split
22.	G Ferrite B Ferrite Core Not Split
23.	G EMI Shield Controller Screen

To help in placing your order:

* Prefix part number with one of the following sign sizes:
"S" (Small/Size 1), "M" (Medium/Size 2), "L" (Large/Size 3)

- Specify one of the following sign types:
L-858Y ("Y"ellow), L-858R ("R"ed), L-858L ("L"ocation), or Blank/ Black
- Specify one of the following track colors:
(B) Black, (Y) Yellow or (R) Red



Certified to current FAA Advisory Circular 150/5345-44
Specification for Runway and Taxiway Signs
View our FAA Certificate of Conformance

LED LIGHTING SYSTEM
Electrical Wiring Diagram

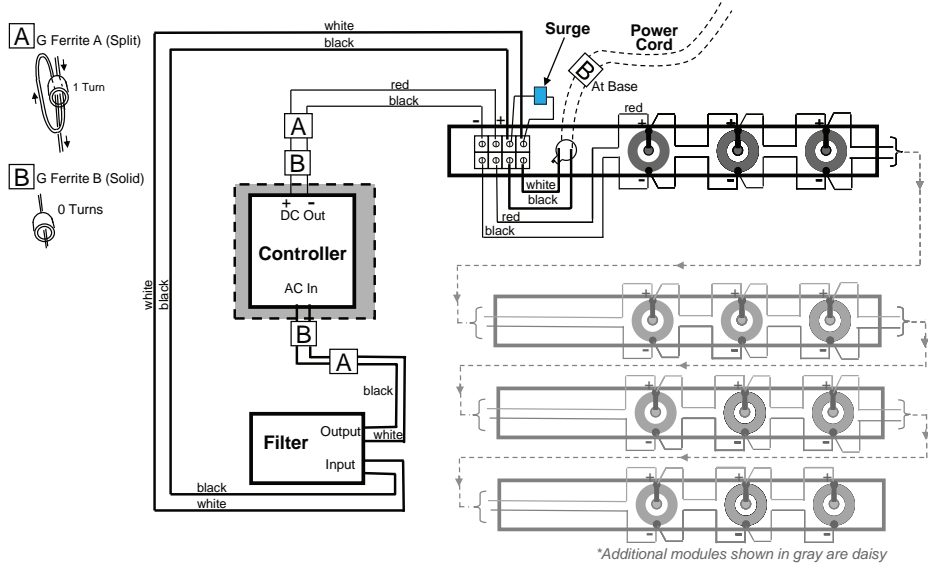

On/Off Switch Wiring

LED Sign - NO SWITCH

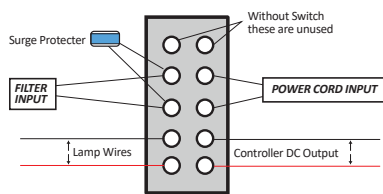

LED Sign - SWITCH

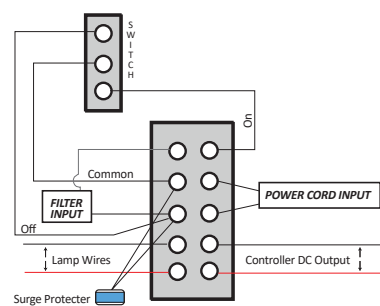

Installation Instructions
Pad dimensions & mounting locations
Sign Sizes: 1, 2, 3 & 5

Standard Mode 2 Installation (Inner Mount)

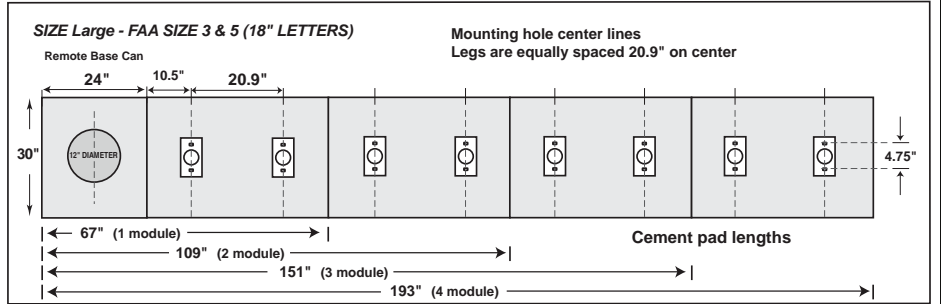
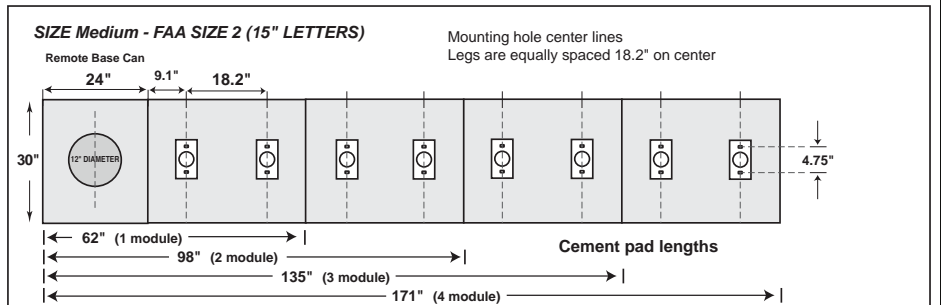
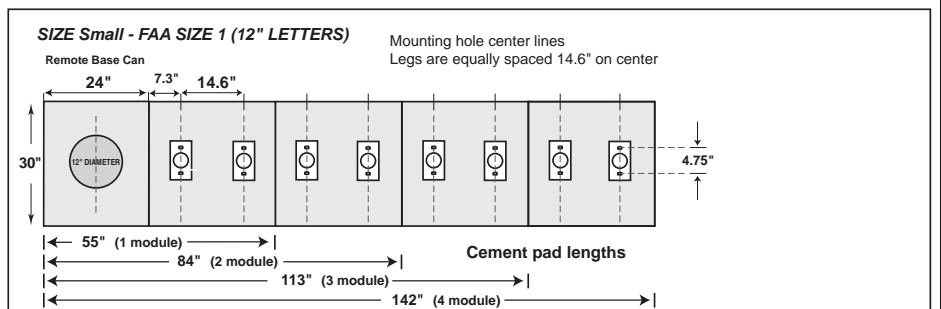

Above references recommended cement pad dimensions and mounting bolt locations for Lumacurve signs
*Recommended concrete thickness : 6"-8"
*Recommended anchor bolts: 3/8" x 5" with LOCK washers