



Manufacturer of the First FAA Sign In 1955

Visit our [YouTube Channel](#) to watch how easy it is to install a Lumacurve LED Upgrade Kit!



Installing: Lumacurve LED Upgrade kits

Installing Lumacurve LED Upgrade kits Replacing Existing Lighting Systems - Sizes 1, 2, 3, 5

The purpose of this guide is to help contractors and airfield personnel install Lumacurve LED Upgrade Lighting Kits into existing Lumacurve airfield guidance signs. Work through the steps below and if you have any problems, don't hesitate to call us for technical support at 800-258-1997.

We recommend reading through the entire instructions first and familiarizing yourself with the procedures before beginning the installation.

NOTE: Using Non-OEM after-market parts will void FAA Certification and void manufacturer warranties.

WARNING: The sign must be de-energized before working on Lumacurve airfield guidance signs, unless otherwise instructed. Failure to do so may result in personal injury or damage to internal sign components.

Recommended tools:

Small Standard Screwdriver
#2 Phillips Screwdriver
7/16" Combination wrench

Power Drill
Drill Bits: 13/64", 1/4", 5/32", 1/8"
3/8" Socket Wrench or Nut Driver

Rubber Mallet
Pop Rivet Tool 1/8"

1. Removal of existing lighting system

- a) Remove sign tops and all panels.
- b) Unscrew power cord leads and remove from terminal strip. *(Photo #1)*
- c) Loosen the set screw on the strain relief clamp *(Photo #2)* and pull the length of the cord out of the clamp. Lay cord on bottom of sign for reconnection once LED light bars are installed.
- d) Remove all the screws that attach the light bars to the vertical sign frame components
(Tools: 3/8" socket or nut driver and #2 Phillips screwdriver).
- e) Remove the light bars from the sign.

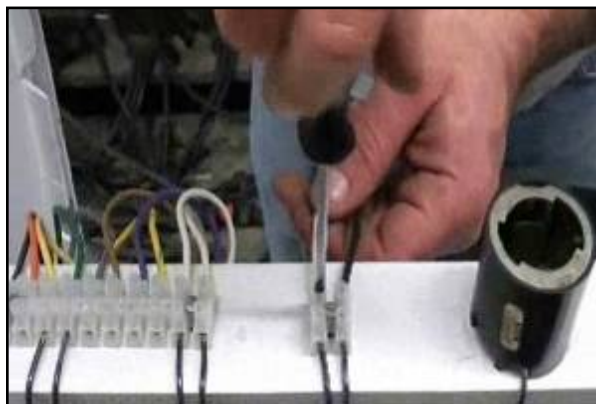

Photo #1

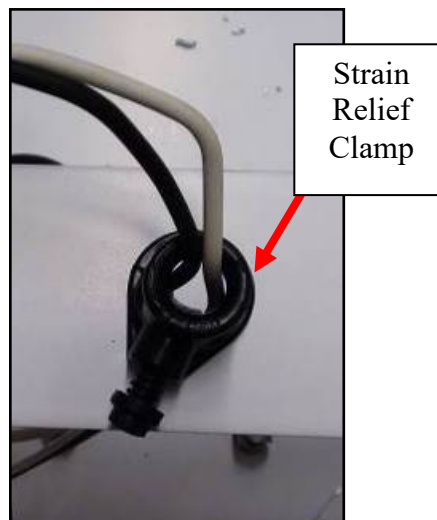

Photo #2

2. Installing the LED Light Bars

- a) Reinstall the tops and tighten all the turn fasteners.
- b) After tightening turn fasteners, take a rubber mallet and give a firm tap to the top of the end panel on both sides of the sign. *(Photo #5) Note: Reinstalling the tops properly and eliminating any gaps, prior to mounting the light bars, ensures that the sign frame is aligned and the legend panels will fit squarely (and smoothly) into the frame.*
- c) Place the light bar with terminal strip and strain relief clamp into position first. The terminal strip end must be installed closest to the power cord. *(Photo #3)*
For multiple module sign, the light bars are connected with continuous wiring. Additional modules must be fed through the tree branches to place into position. For size 2 (medium) and size 3 (large) signs, the light bars of the additional modules must pass below the center branch of the trees *(Photo #4)* and installed in order. For size 1 (small) signs, pass the light bars below the bottom branch.
- d) With the light bars in place, drill through the pilot holes of the new light bars with a 13/64" drill bit. After every drilled hole, replace the screws before drilling the next hole. *(Note: If screws are not replaced as holes are drilled, the lightbar may move between holes. Misaligned holes cause difficulties when replacing screws.* Place lock washers and nuts (or nyloc nuts) on the screws on the underside of the light bars. Tighten them with a 3/8" socket or nut driver and #2 phillips screwdriver. *Note: Tops can be removed again to allow more light and headroom while completing the installation.*

Terminal Strip

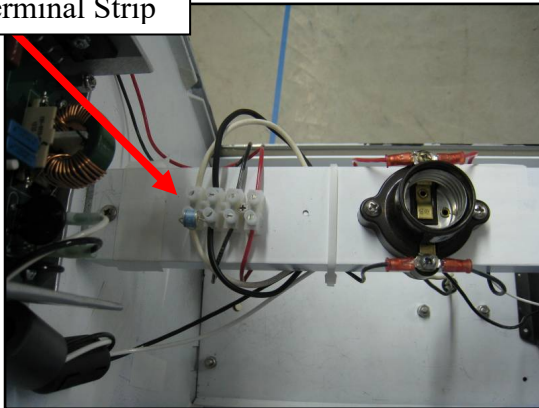

Photo #3

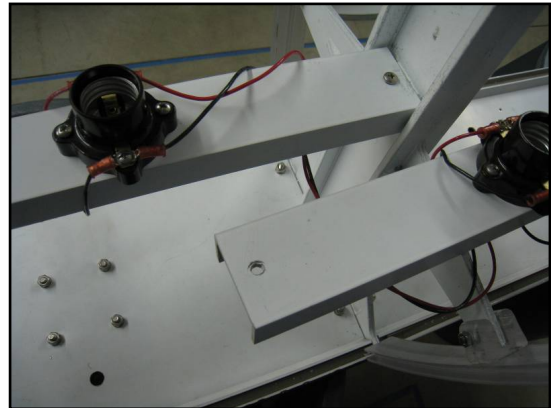

Photo #4



Photo #5

3. Installing the Controller

The Controller is to be mounted on the end panel closest to the power cord.

- a) Position the “LED Controller Mounting Hole Template” (Figure #19) on the end panel, closest to the power cord (above the lightbar). Using a 1/8” drill bit, drill lightly to mark the hole location (this will ensure the template will not wear out). Now using a 13/64” drill bit to enlarge the two (2) mounting holes (upper left and lower right).

Warning: Do not drill through the actual mounting holes of the controller with the controller in place! There is a very high risk of doing damage to the controller. **Note:** The controller needs to be a least 2” above the lightbar to keep the controller and filter screen from interfering with the surge protector (Photo #6).

- b) Remove the template. The template should be used for multiple LED Controller installations.
- c) Insert the two 8-32 x 1-1/4 bolts from the outside of the end panel.
- d) While holding the bolts in place, slide the controller over the bolts. **Note:** Controller DC outputs must be oriented toward the top of the sign, AC inputs to the bottom.
- e) Tighten and secure controller in place using the enclosed nyloc nuts.

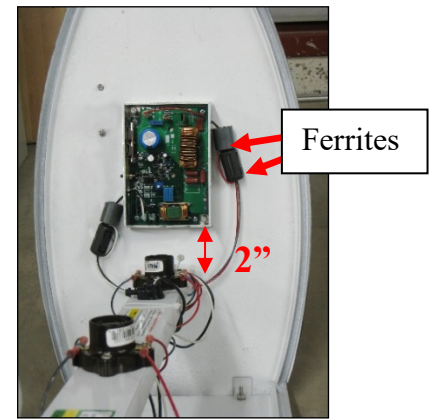

Photo #6



Figure #19

4. Installing the Filter

- a) Place the filter on the sign base (underneath the light bar) of the power leg module.
- b) Orient the wire side of the filter to face the controller. Adjust the position of the filter to be approximately 13” from the end panel. (Photo #7).
- c) Adjust the position of the filter to be approximately 2.5” from the inside edge of the sign base on one side and approximately 3” from the inside edge of the sign base on the other side (Figure #8).
Warning: Do not center the filter between the two edges of the sign base! There are two reinforcement ribs running the length of the sign base inside its double wall. Centering the filter runs the risk of drilling into the ribs.
- d) Even though the filter has four holes for mounting, only two are required to hold the filter in place. Mark two hole locations diagonally across from each other. Remove the filter, locate the marked hole locations then drill using a 5/32” drill bit. **Note:** the sign frame base is double-walled. Only drill through the top (interior/white) wall.

- e) Place the filter back in to place and secure using the enclosed #8-5/16” x 1/2” x 1/8” screws.

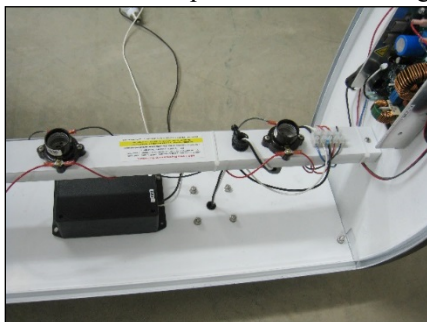

Photo #7

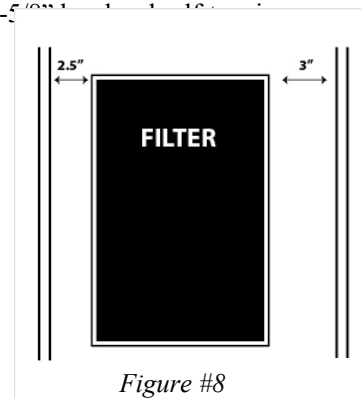

Figure #8

5. Reinstalling the Power Cord

- a) Feed the power cord through the ferrite provided and then through the strain relief clamp (*Photo #9*) from the underside of the lightbar. Pull the power cord taught removing any slack between the bottom of sign and the cable clamp. As required by the FAA, this ensures the power cord will disconnect at the plug in the frangible sign leg in the event the sign is knocked over.
- b) Tighten the set screw on the strain relief cable clamp (*Photo #10*). Do not over tighten.
- c) Reinstall the power cord leads on the two terminals on the power strip opposite the surge protector (*Figure #11*). Excess slack in power cord can be trimmed to fit or coiled and zip-tied to the underside of the lightbar. This will eliminate any potential shadowing from excess wire onto the panel faces.

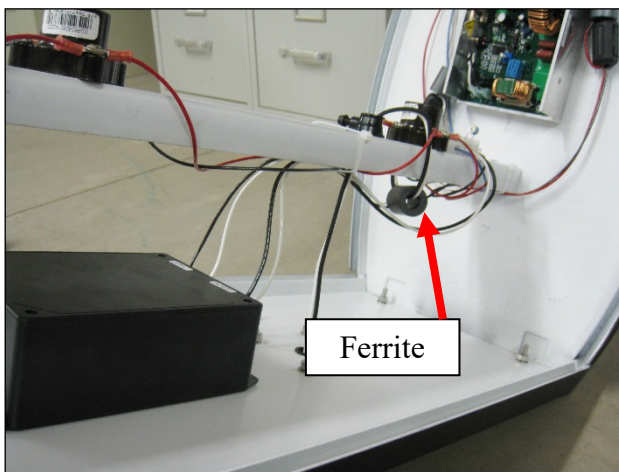

Photo #9

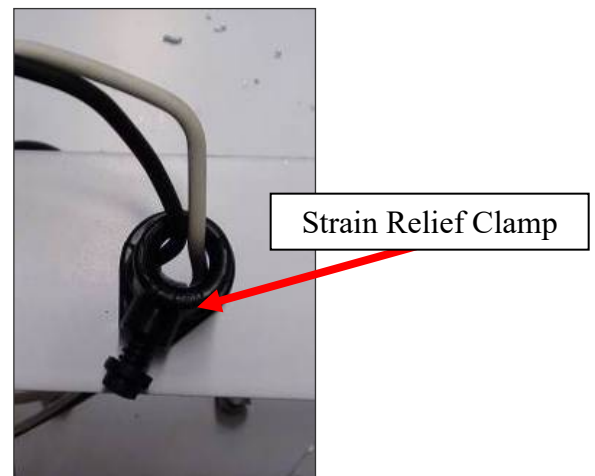
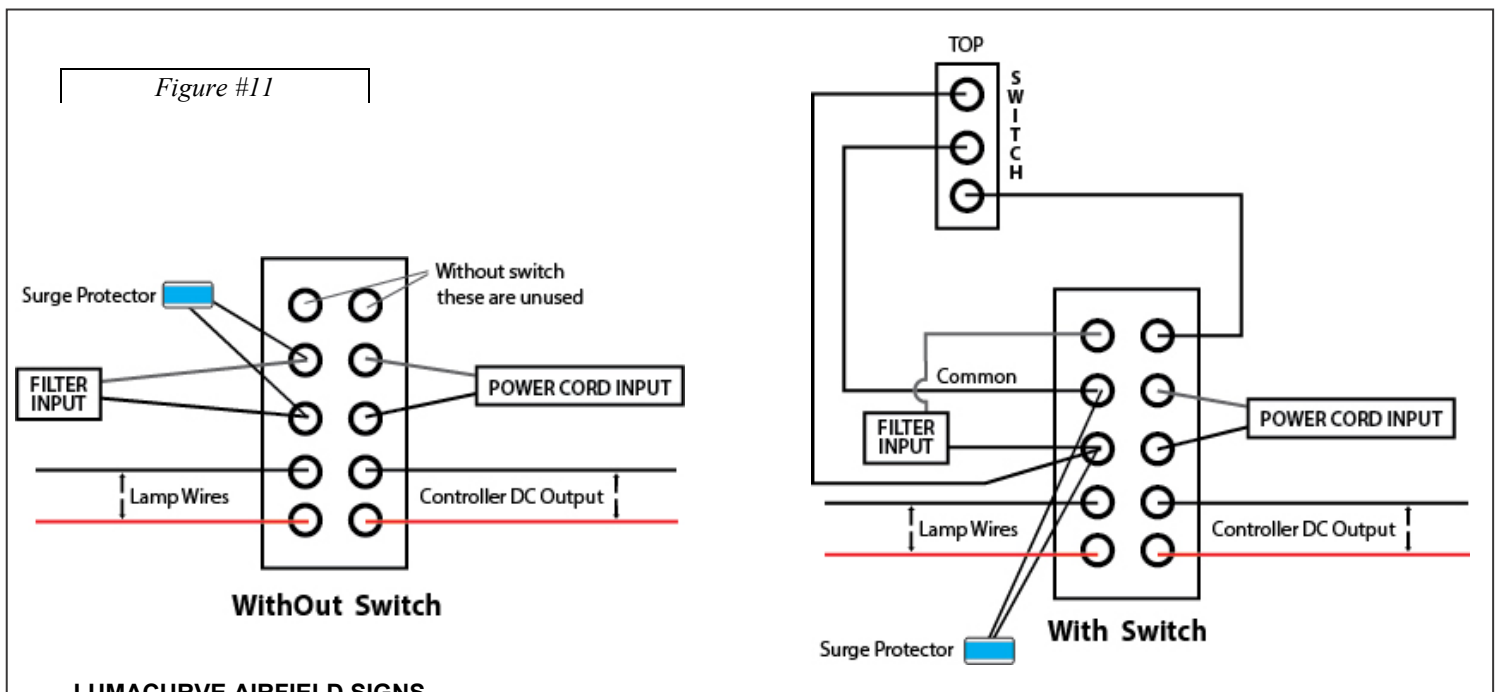

Photo #10



LUMACURVE AIRFIELD SIGNS

9115 Freeway Drive, Macedonia, OH 44056
330.467.2076 www.lumacurve.com

6. Connecting the Filter and Controller

- a) Identify the filter input leads. Install these leads into the terminal strip opposite of the power cord leads. These leads must be installed in parallel with the surge protector (*Figure #11*). These connections are not polarity sensitive.
- b) Identify the filter output leads. These will have two factory installed black ferrites. Route these leads through the hole on the lower left side of the controller (*Photo #12*) and connect to the AC input of the controller (*Photo #13*). These connections are not polarity sensitive.
- c) Identify the DC controller output leads, factory installed on the controller (*Photo #14*) with two black ferrites. Connect these two leads to the terminal strip (*Figure#11*). These leads are polarity sensitive. Red lead is (+). Black lead is (-).

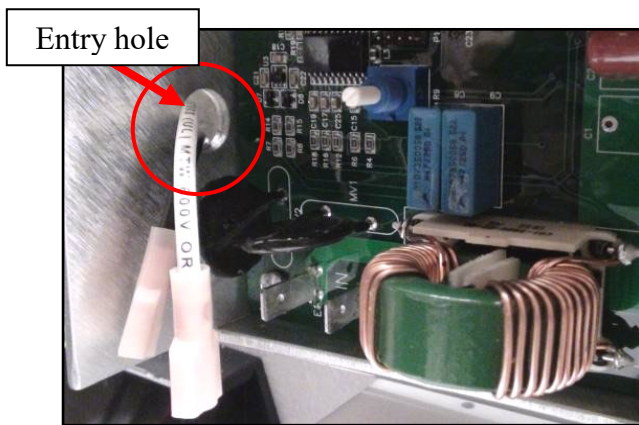

Photo #12

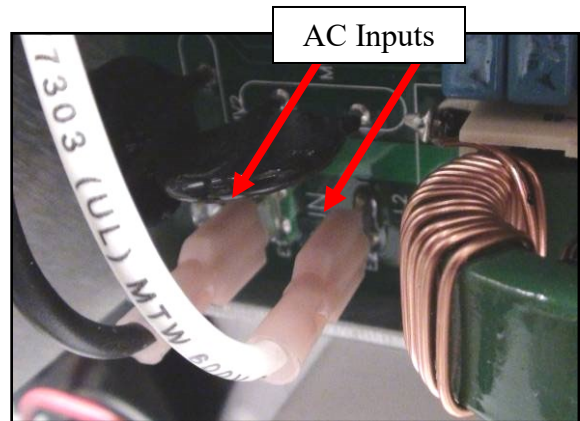

Photo #13

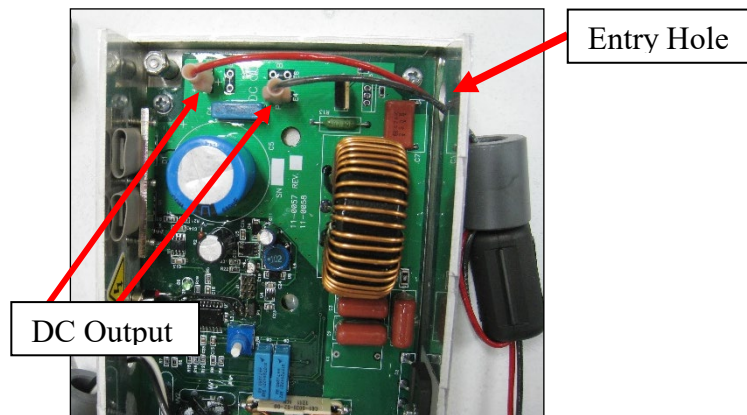
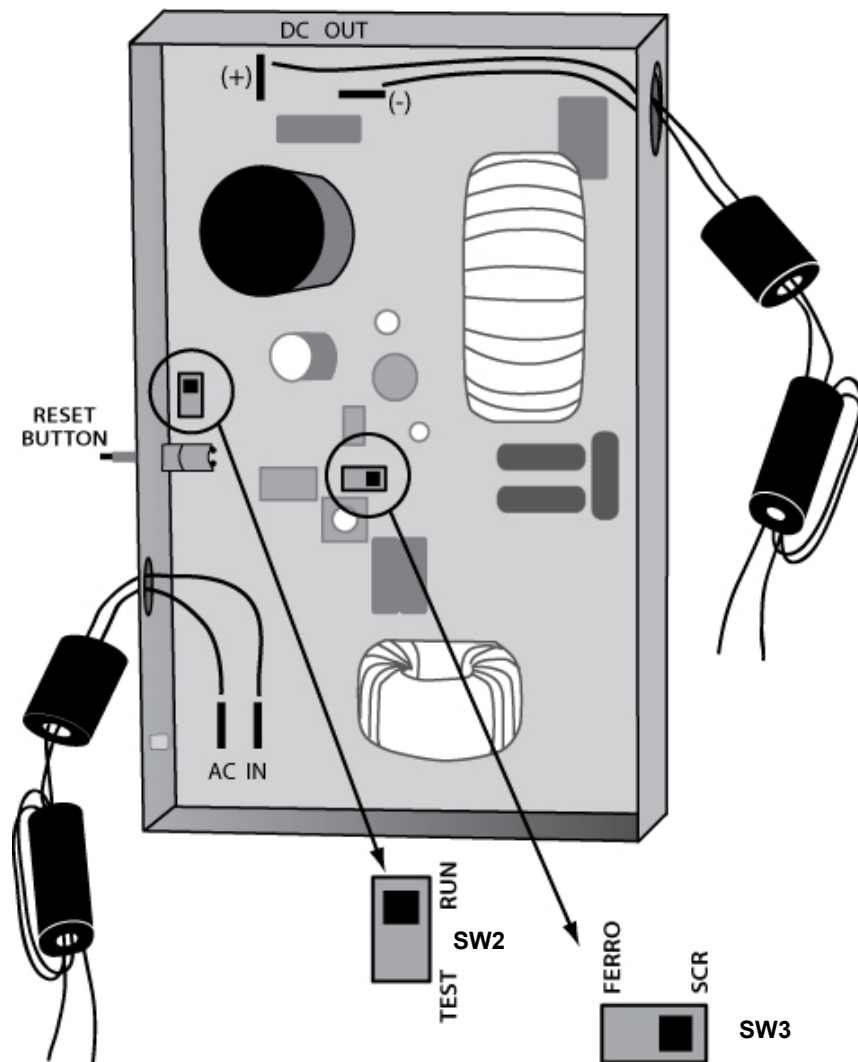

Photo #14

7. Using the switches on the L610 Controller

- Switch **SW2** (Run & Test) is used to isolate controller programming functions when troubleshooting (One out, all out).
- Switch **SW3** (Ferro & SCR) is used to set controller functions with constant current regulators (CCR's)



8. Installing the Shielding Screen

On each side of the controller are screws and fender washers (*Photo #15*). These hold the shielding screen in place. If the fender washers are tight to the side of the controller, loosen them slightly to slip the edge of the screen between the fender washer and the controller case (*Photo #16*). The shielding screen is shaped to precisely fit the controller. Once the screen is in place, tighten the screw & fender washers to secure screen. The screen is installed to shield out radiated emissions (*Photo #17*).



Photo #15

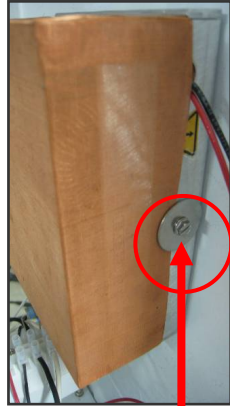

Photo #16

Fender washer and screw serves as a clamp to hold the shielding screen in place

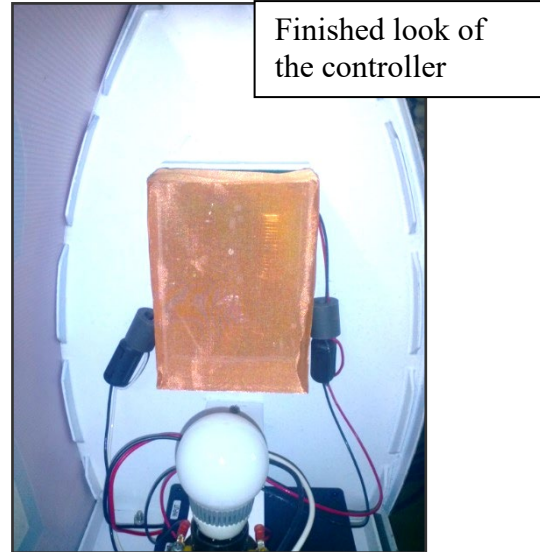

Photo #17

Finished look of the controller

9. Installing the OEM Electrical Upgrade Nameplate

Each Lumacurve LED Upgrade Kit contains an OEM Electrical Upgrade Label (*Photo #18*) and (2) 1/8" pop-rivets. Information on this label is critical for future sign maintenance. This label should be mounted to the sign end panel (power side of sign) just below the original factory nameplate.

- Be careful not to come into contact with any components mounted on the inside of the end panel. Carefully position the OEM Electrical Upgrade Label just below the original factory nameplate. While holding the label in place, use a 1/8" or 9/64" drill bit to drill through the two holes in the label.
- Install two 1/8" pop-rivets to secure the label in place.

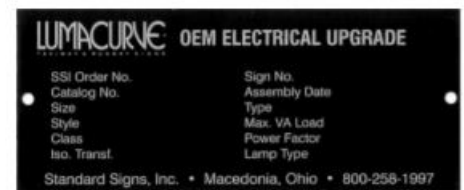

10. Checking system & restoring the sign to service

The electrical components should now be mounted and wired properly.

- a) Insert all lamps into the sockets.
Warning: the use of non-OEM replacement lamps may damage electrical components and cause premature lamp failure. Only OEM Lumacurve lamps will maintain FAA photometric requirement and factory warranties.
- b) Check that the properly sized isolation transformer is being used. *See chart.*
- c) Power up sign and check that all lamps are functioning properly.
Note: If sign is not functioning, revisit above steps once again to ensure the sign is wired properly. If there are still problems, contact us for technical support at 800-258-1997 or visit our [Help Yourself Center](http://www.lumacurve.com/helpyourself) for videos and troubleshooting documents at www.lumacurve.com/helpyourself
- d) Reinstall all the legend panels. Replace and secure all sign tops.

Use the chart below to identify the proper size isolation Transformer:

		FAA Style 2 (4.8A-6.6A) FAA Style 3 (2.8A-6.6A)			FAA Style 5 (5.5A)			
SIGN SIZE & MODULE LENGTH	LAMPS	4W LED			4W LED			
		ISO XFMR	MAX VA	POWER FACTOR	ISO XFMR	MAX VA	POWER FACTOR	
Size 1, 1-mod	2	100W	49	.94	100W	37	.94	
	2-mod	4	100W	64	.88	100W	48	.89
	3-mod	6	100W	67	.89	100W	50	.90
	4-mod	8	100W	73	.90	100W	56	.91
Size 2, 1-mod	3	100W	62	.87	100W	46	.88	
	2-mod	6	100W	67	.89	100W	50	.90
	3-mod	9	100W	74	.90	100W	58	.92
	4-mod	12	100W	78	.91	100W	62	.93
Size 3, 1-mod	3	100W	62	.87	100W	46	.88	
	2-mod	6	100W	67	.89	100W	50	.90
	3-mod	9	100W	74	.90	100W	58	.92
	4-mod	12	100W	78	.91	100W	62	.93
Size 5, 1-mod	3	100W	62	.87	100W	46	.88	
Size 4, 1-mod	6	100W	67	.89	100W	50	.90	

LUMACURVE AIRFIELD SIGNS

9115 Freeway Drive, Macedonia, OH 44056
 330.467.2076 www.lumacurve.com