



Installation Instructions

Size 4 Distance Marker Signs

— DO NOT DISCARD —
Important information for AIRPORT MAINTENANCE DEPT

To install:

1. Locate the power cord (#1). It will be visible protruding from the power leg slipfitter aluminum column and coupling.

Note: in a typical remote L867 base can installation, the sign leg is connected to the remote can with 2" rigid galvanized steel (RGS) conduit. An isolation transformer secondary extension cord (#3) is fed through the conduit and connects the sign power cord plug to the isolation transformer secondary plug.

2. Locate the cable clamp (#4, provided with the sign for most new sign installations). Tighten the cable clamp (#4) onto the isolation transformer secondary extension cord female plug at grade level. Ensure the cable clamp side labeled "TOP" is facing up. The cable clamp should nest on the under side of the floor flange (#2) and on top of the conduit (#5) that is flush with the surface of the concrete mounting pad. Insert the power cord plug (male) into the isolating transformer secondary extension cord plug (female).

Note: As required by the FAA, this ensures that the power cord will be disconnected/unplugged in the event that the sign is knocked over.

3. Lift the sign upright into place on the cement pad. Use the sign as a template to locate and mark mounting holes. Place sign off to one side and install anchor bolts. Recommended anchor bolts: 3/8" x 5" for mode 2 signs, 1/2" x 5" for mode 3 signs. Position sign over the anchor bolts and fasten the floor flanges to the cement pad with lockwashers and nuts.

4. Electrical adjustments are now required. Power supply settings have been factory set but must be rechecked with an RMS meter once installed in the airfield environment. Please refer to the "Parts & Electrical Information" sheet for the lighting system being installed. Follow the "Installation" portion of those directions to ensure that the electrical settings are correct.

5. Replace any covers or access doors that had been removed.

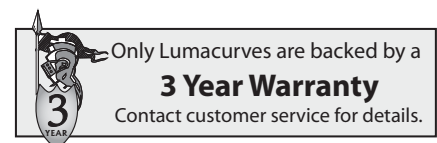

STANDARD SIGNS, INC.

9115 Freeway Drive, Macedonia, OH 44056
Phone: 800.258.1997 / 330.467.2030 Fax: 330.467.2076
www.lumacurve.com

Copyright 2012 by STANDARD SIGNS, INC. ALL RIGHTS RESERVED.

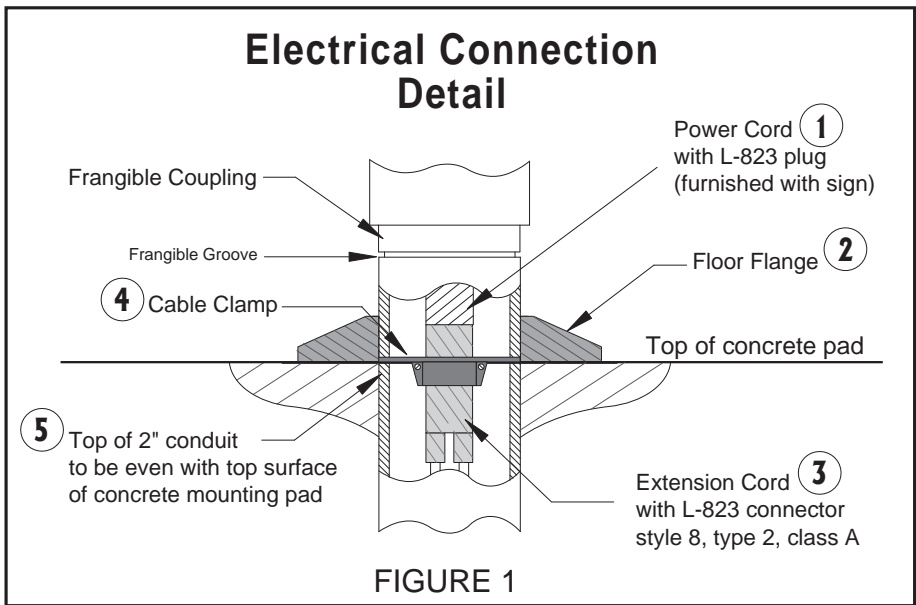
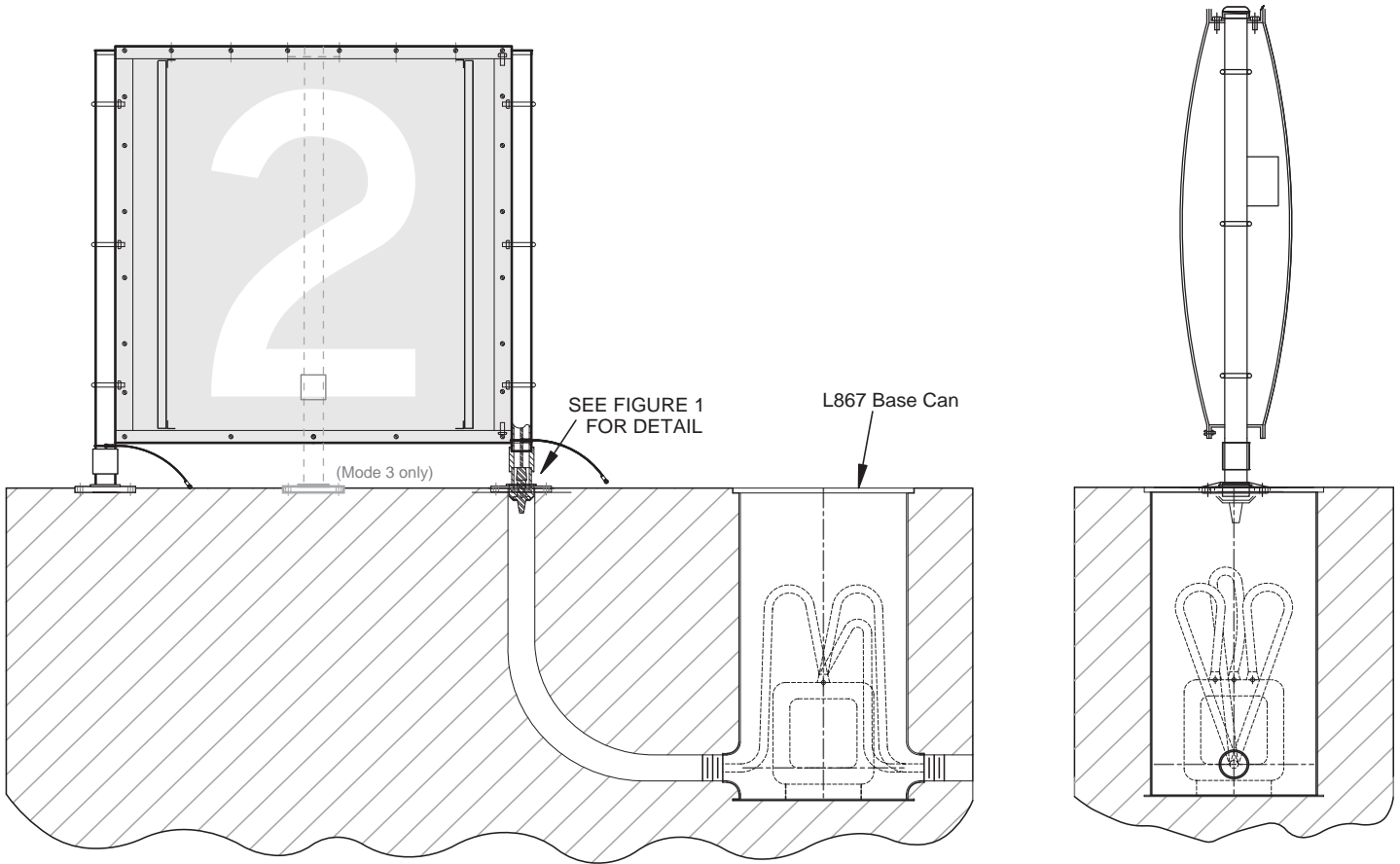



Installation Guidance, Size 4 Distance Remaining Sign

Section G: "Distance Markers & Unlighted Signs"

DO NOT DISCARD
Important information for AIRPORT MAINTENANCE DEPT

Installation of LUMACURVE Size 4 Distance Remaining Signs should be in accordance with FAA Advisory Circular 150/5345-18. A pad dimension sheet is available upon request. Separate literature sheets on lighting system technical information and adjustment guidance are available upon request. See **Distance Remaining Signs Technical Information** sheet for details on sign construction and parts.

WARNING: LUMACURVE Distance Remaining signs with lighting systems that use 30V/50W Train lamps or 20W quartz lamps are designed to operate on circuits along with other lighting fixtures that represent resistive load, such as non LED edge lights. They may not operate properly on circuits dedicated exclusively to airfield signs. For lighting systems designed for dedicated sign circuits, please see information on style 5 lighting systems described in the **LUMACURVE Taxiway and Runway Guidance Sign Installation Instructions** pamphlet.

TO INSTALL:

VERY IMPORTANT: Lock out power to the site before installation.

1. Carefully lay sign on its side near the isolation transformer housing in the mounting pad.
2. If a base plate and/or floor flange(s) are not on the sign, install them now.
3. Check the tightness of the frangible couplings and pipe couplings. Be careful! Too much torque on the couplings can cause damage to the sign. Couplings, however, should be adequately tight.
4. Verify that the isolation transformer wattage matches the requirement listed on the sign ID tag. Place the isolation transformer in the housing and connect the secondary lead to the sign plug. Clamp the knob in the bottom of the base plate.
5. Connect the isolation transformer to the primary circuit.
6. Lift the sign upright and position it over the transformer housing and/or floor flange mounting studs and tighten down. If lag screws are being used, they can be located and installed now.
7. Draw the power cord slack up into the sign so that the sign will unplug in the base plate if the sign is knocked over.

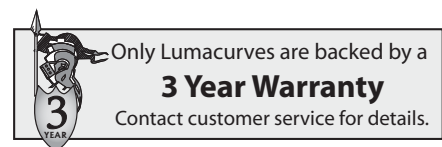

STANDARD SIGNS, INC.

9115 Freeway Drive, Macedonia, OH 44056
Phone: 800.258.1997 / 330.467.2030 Fax: 330.467.2076
www.lumacurve.com

Copyright 2012 by STANDARD SIGNS, INC. ALL RIGHT RESERVED.

10/11
g20. Installation, Size4DistanceMarker

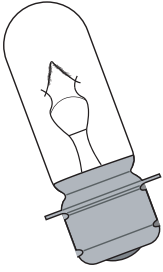

LUMACURVE PARTS LIST

Size 4, Distance Remaining Sign Style 5 T10P Quartz Lighting Systems

Certified to current FAA Advisory Circular 150/5345-44
Specification for Runway and Taxiway Signs
View our Certificate of Conformance

T10P Lighting System

	<i>Item</i>	<i>Description</i>
1a.	DCLT-1A	Leg Cap
* 1.	D-1	Leg
2.	D-2	Top/Bottom Channel
3.	DTG-2	End Panel
* 4.	D-4AB	U-Bolts w/ nuts & washers
5.	D-4ABC	Access Door (handle on power side)
6.	215/220/230/232	1/4" Hardware
7.	394	1/4" x 3/4" Hex Head
8.	D8P	Light Bar Channel (Vertical)
9.	D-15	48" x 48" legend panel
10.	6.6A/T10P	T10P Lamp
11.	400	T10P Socket
12.	420	Terminal Strip (2 block)
18.	2" Al Coupling	2" Pipe Coupling
* 19.	140A	Frangible Coupling-2600 ft/lbs
* 20.	2234G	Circular Floor Flange (Galv, 4-hole)
21.	CLT-19	Tether
22.	430	Cord & Plug
25.	480	Cable Clamp

**Best Service
in the Industry!**

Try our "Wait-Less" service!
Call by 10 am and complete signs and/or
parts will ship that same day!!
NO EXTRA CHARGE!
Call 800-258-1997

** Mode 3 parts may be different.
Please call for more information.*

STANDARD SIGNS, INC.

9115 Freeway Drive, Macedonia, OH 44056
Phone: 800.258.1997 / 330.467.2030 Fax: 330.467.2076
www.lumacurve.com

LUMACURVE PARTS LIST

Size 4, Distance Remaining Sign

Style 5 T10P Quartz Lighting Systems

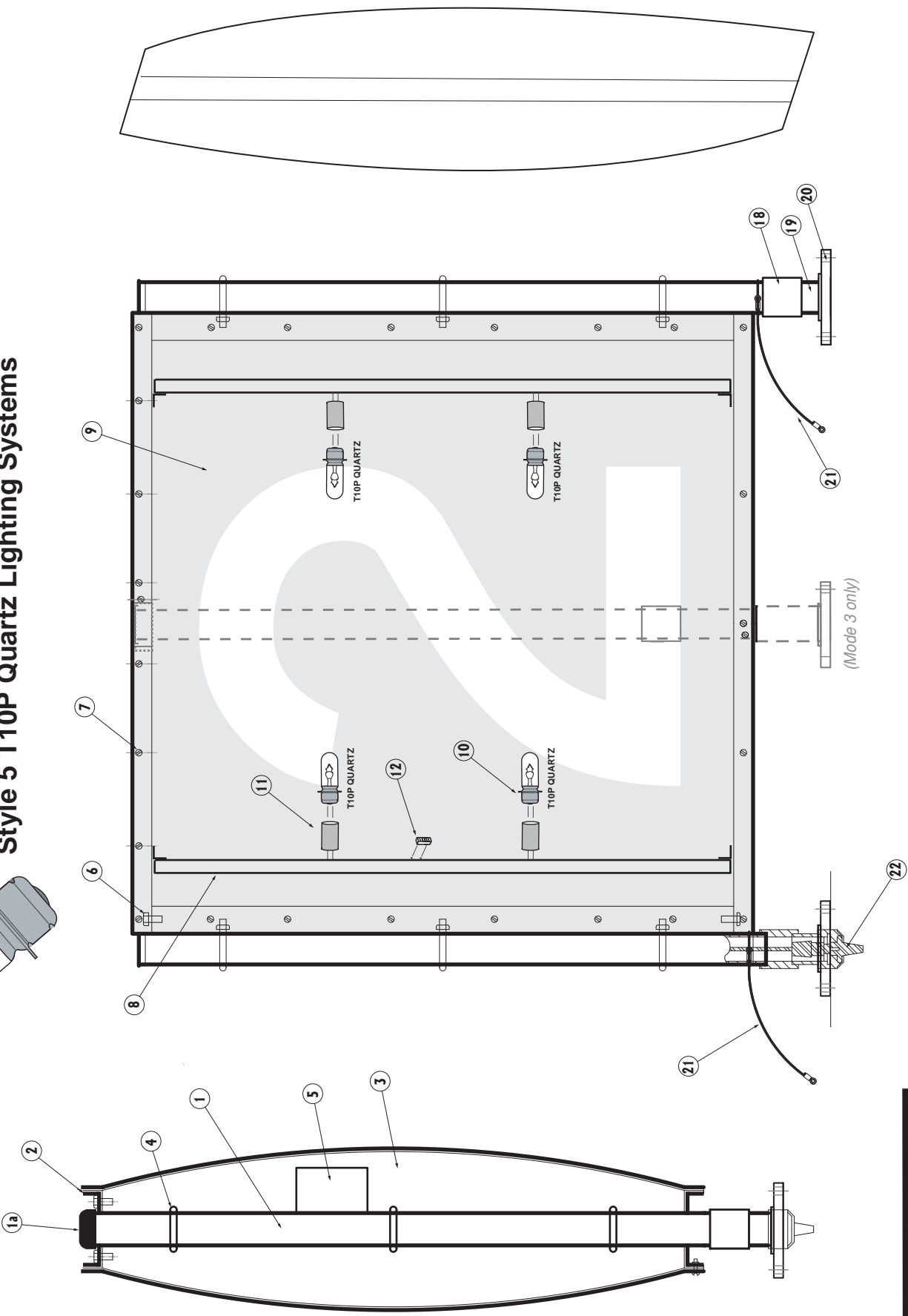
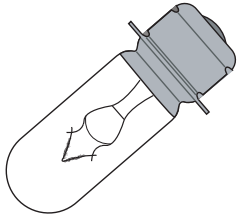

STANDARD SIGNS, INC.
 9115 Freeway Drive, Macedonia, OH 44056
 Phone: 800.258.1997 / 330.467.2030 Fax: 330.467.2076
www.lumacurve.com

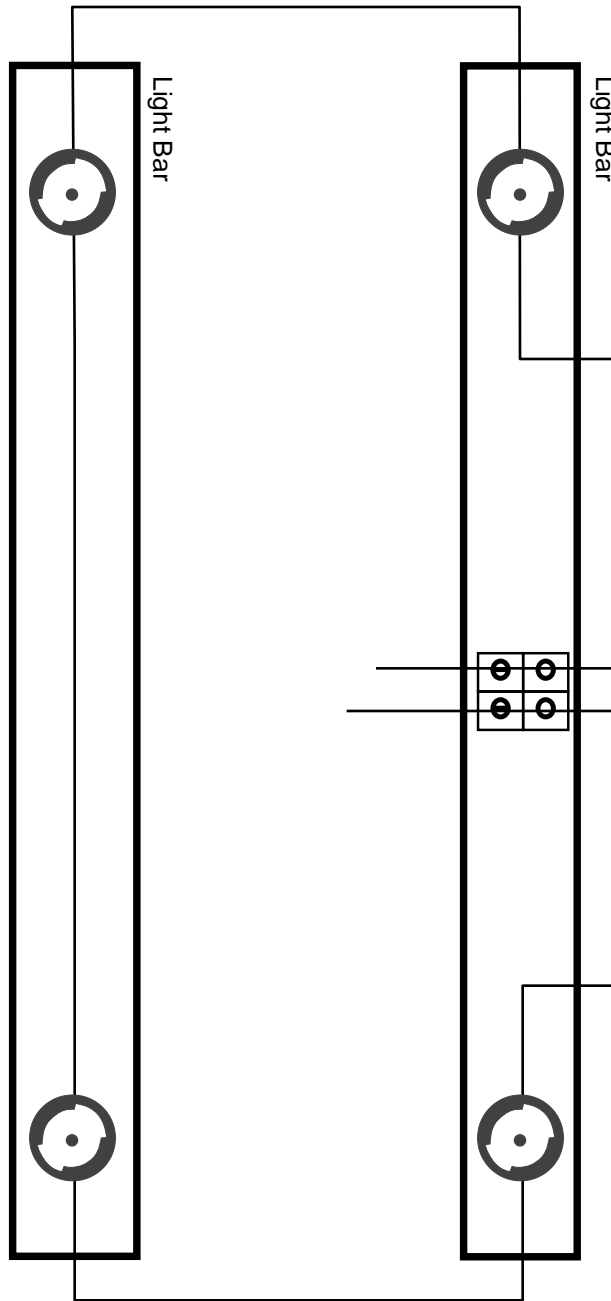

T10P VA Load, Power Factor and Isolation Transformer

		EXM Quartz Lighting System		
		FAA Style 5 (Constant 5.5A)		
Sign Size & Module Length	Lamps	45W/T10P		
		Isol Xfmr	Max VA	Pwr Factr
Size 4, 1-mod	4	200W	127	0.99

STANDARD SIGNS, INC.

9115 Freeway Drive, Macedonia, OH 44056
 Phone: 800.258.1997 / 330.467.2030 Fax: 330.467.2076
 www.lumacurve.com